

## The insurance **to deliver** **100%** tapped parts

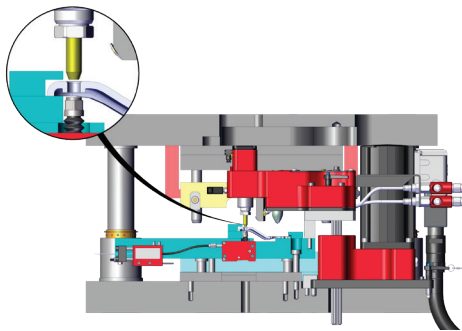

Top Dead Center

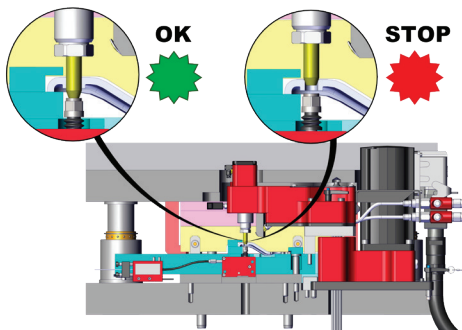

Bottom Dead Center

**DETEC: the most affordable "on the shelf" tap detection system; making tap detection easy for both designers and final users.**

This is the 3rd generation of our patented and compact detection system. It guarantees 100% of the parts are tapped.

DETEC V3 is even more compact for trouble-free installation, regardless of the tool, offering better sealing thanks to dedicated seals, for reduced maintenance. It is compatible with oils containing sulfur or chlorine.

DETEC closely monitors the accuracy of your tapping operation, eliminating the need to sort your parts out because of broken taps, a pre-hole too small, or a miss feed.

Though completely mechanical, DETEC includes a mechanical sensor that amplifies the motion of the tap to detect even the smallest movement. Then, the signal is transmitted through a flexible cable to a mechanical receptor installed outside of the die. Easily mounted, the sensor and the "prox switch/ detector" are connected to your press control panel to stop the press if a problem occurs.

### ADVANTAGES:

- **Detects** tap breakage, misfeed, wrong tap set-up and short tap travel.
- **Visual light** (LED) when activated by the tap.
- **100% mechanical** for reliability.
- **Pressure Key** with carbide tip.
- **Adjustable Cable** length (2,36" - 29,53")
- **Limited** servicing
- **Very easy** installation and set-up
- **Very compact** to install into any die

# CHARACTERISTICS:

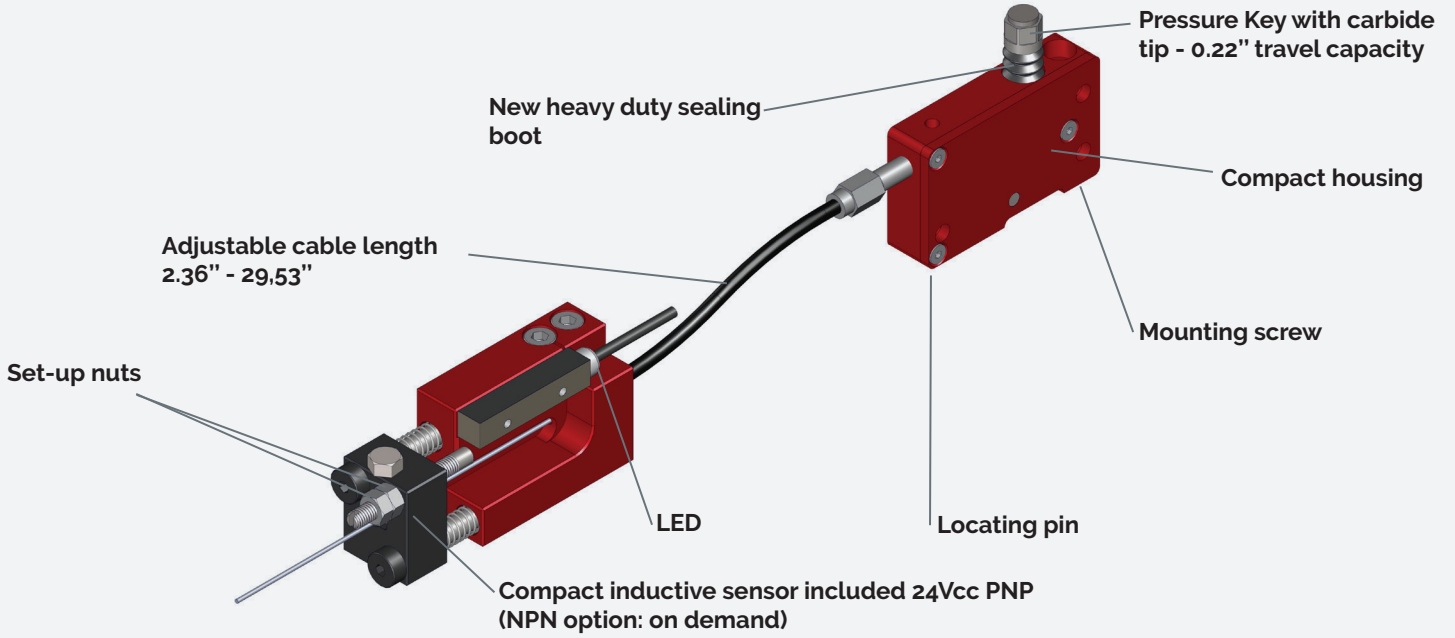

Detection stroke	0.22"	Housing width	0.59"
Cable length	2.36" - 29.53"	Available sensor type	NPN or PNP and NO or NF

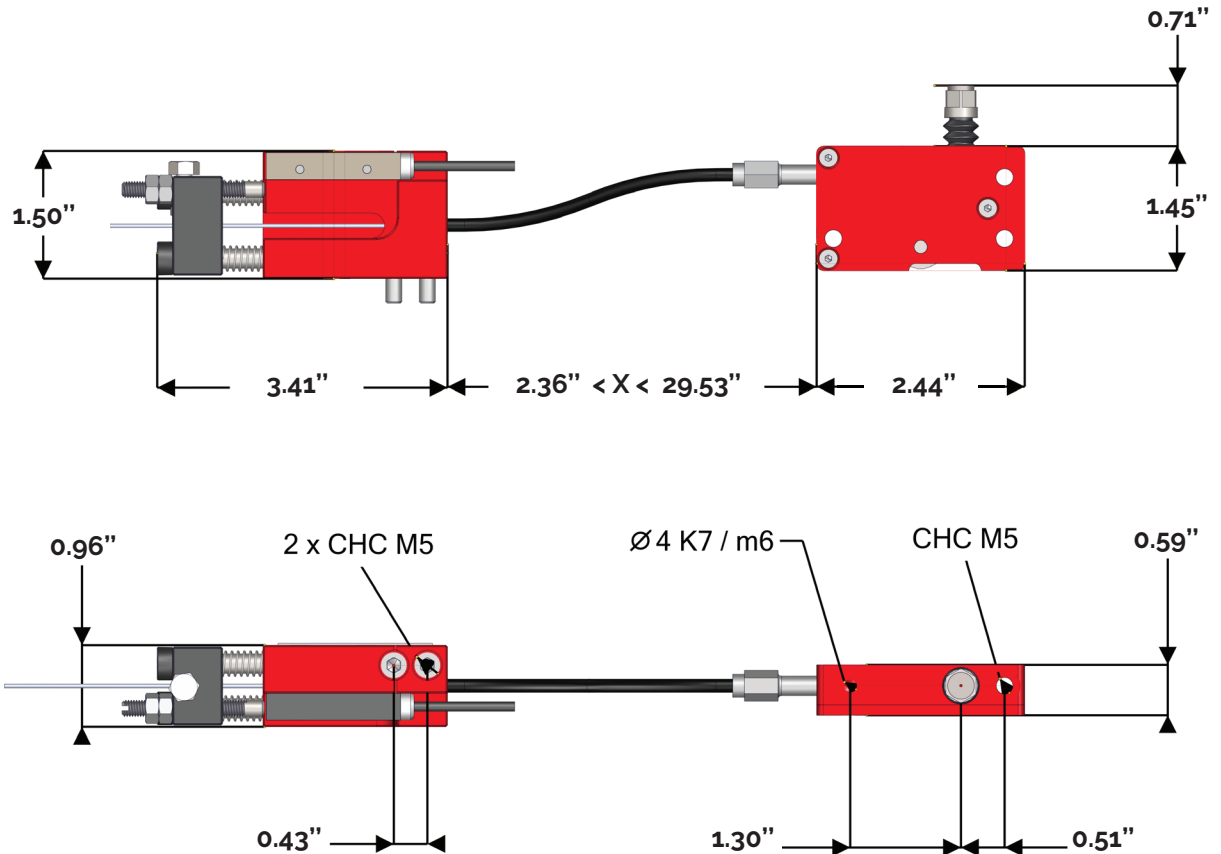

Detec V3 - US - 12/2018 - Eclol/INK