

The most **COMPACT** solution for your **mono-tap applications** **with or without a strip-following feature.**

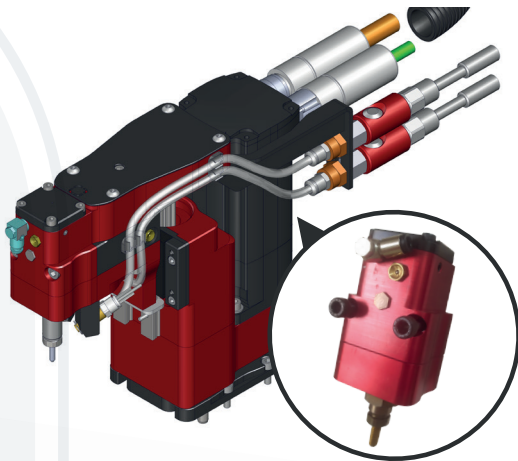

STS1E

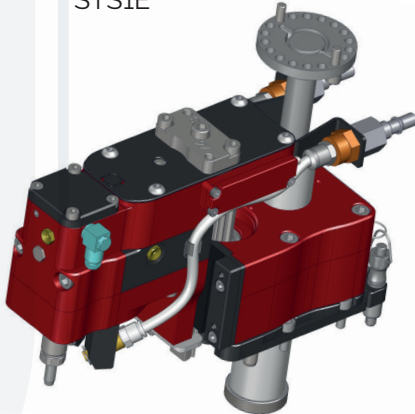

STS1M

The only single tap tapping unit on the market with a detachable tapping head, built-in strip following function and unprecedented possibilities.

These units are designed with a detachable tapping head (with cartridge) to be used for single tap applications. The two-part design makes the handling of the unit much easier and reduces the downtime for tap change.

The ST1 is available with mechanical or servo-drive units, sharing a common body design: vertical movement on a slide ensures softness, precision and repeatability. Its compact design and dimensions (eligible to fit in small shut height) allow it to be installed easily into all types of dies.

For multi-tapping applications, you can also install several tapping devices side by side or staggered in a congested space. Because of the easy and quick in-die installation/setup of the ST1, it can be easily shared in dif-

ferent dies for other applications. Last but not least, because of its design, it can be re-used to tap different small diameters only by using a different detachable head without modification.

The Pronic engineered spindle drive's technology (cartridge technology guarantees precision, accuracy, quality and repeatability of the tapping cycle) has a clutch-safety function which disengages the cartridge to avoid any breakage in the tapping unit.

ADVANTAGES:

- **Ultra-light detachable tapping head** for quick and easy tap change.
- **Integrated strip following feature** to make the die simpler (STS version).
- **Compact design for easy installation** into any type of die.
- **Integrated clutch system with a visual poka-yoke pin** for higher safety and reliability.
- **Sharable in several die applications** due to quick installation and setup.
- **Oil-bath lubrication for optimal performance** (mechanical motorization).
- **Capable of tapping multiple tap size diameters** by changing the detachable head only.
- **Automatic tap setup position** for a quick, safe and easy installation (Auto-Setup)

CHARACTERISTICS:

STS 1M STS 1E

Motorization	Mechanical	Electromechanical
Tapping direction	↓	↓
Kinematic	Mobile	Mobile
Max strip lift	37 mm - 1.45"	
Tapping unit width	80 mm - 3.15"	
Detachable tapping head	●	●
Tap micro lubrication	●	●
Integrated clutch system with a visual poka-yoke pin for higher safety and reliability	●	●
Adjustable gearbox	●	●
Automatic tap setup position (Auto-Setup)		●

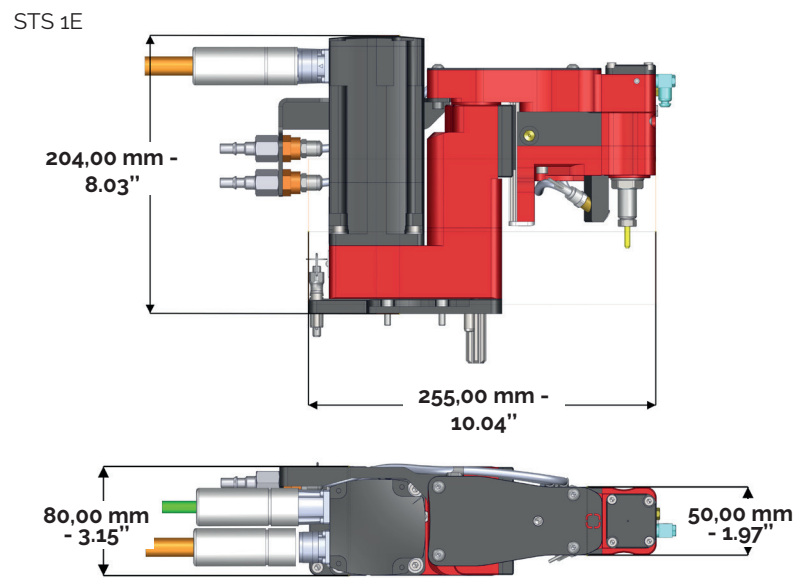
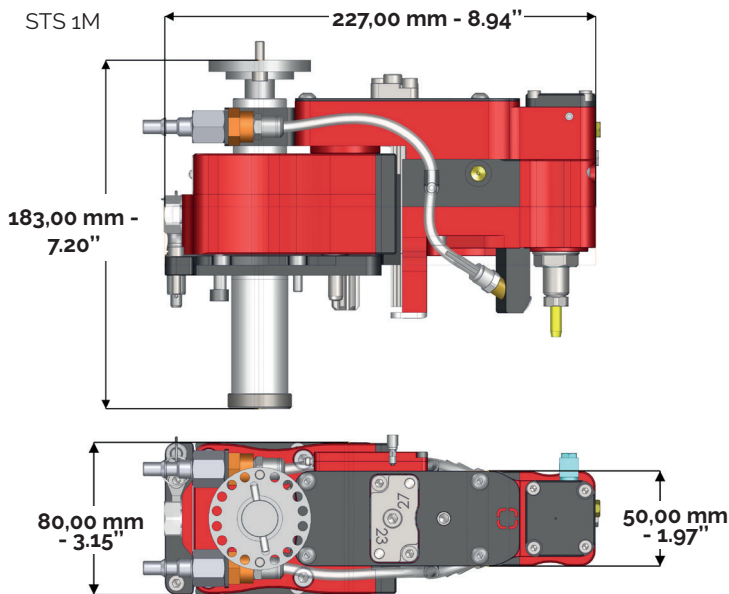

Tap dimension ¹	M3 x 0.5 to M6 x 1.00
Max speed	150 spm
Maxi press stroke ² (mechanical motorization)	330 mm - 13"
Max strip lift	37 mm - 1.45"
Width of the tapping device	80 mm - 3.15"

1 - BSP, TR, G, multi thread taps... are also possible.
2 - For longer Tap travel, please contact us, we will use special lead screw.

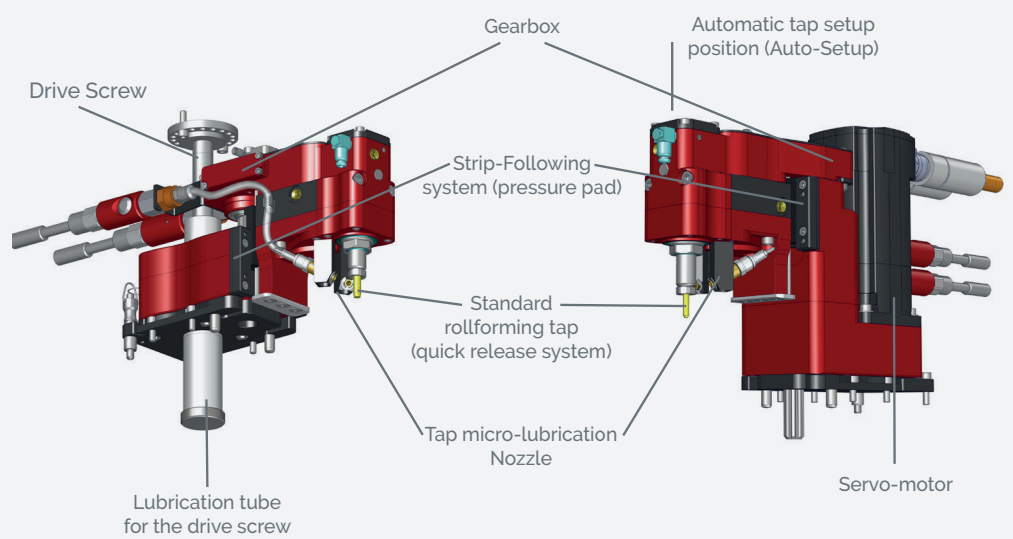

© STI Tapping Unit - US - 09/2021 - EcolINK