

The modular **TAPPING SOLUTION,** easy to integrate and use

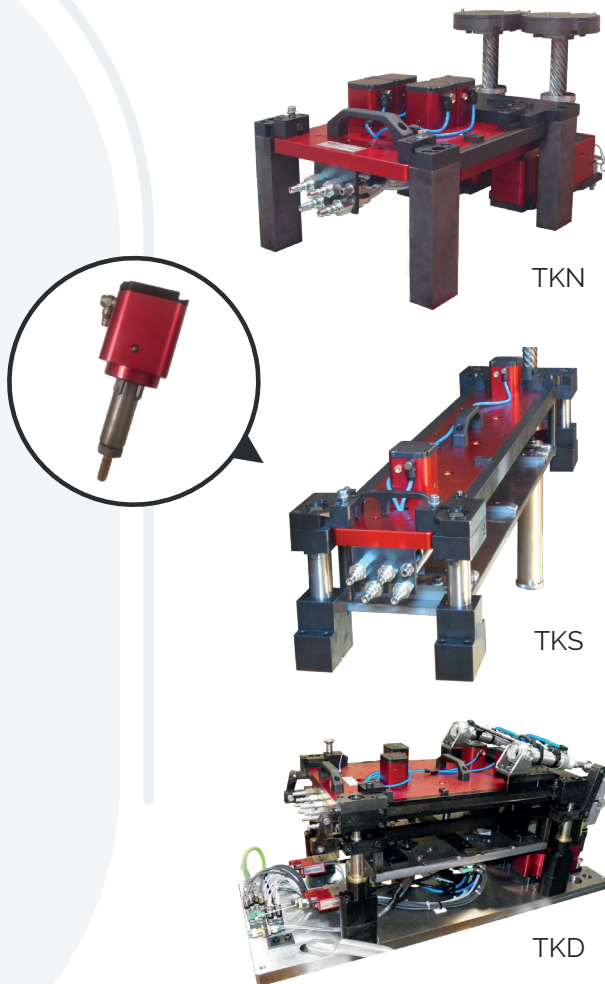

TK (Turn Key) tapping units with removable single or multitap head and built-in mobility functions.

These tapping units are designed with a removable head and may be used for single or multi-tap applications. The tapping head is driven either by mechanical or by servo-driven motorization. The two-part design simplifies operations and enables quick tap change.

These units have been studied to integrate the commonly installed functions in the die directly and compactly in the tapping head.

According to the proposed version, the «TK» solution integrates the following functions:

- Strip guiding,
- Vertical strip follow (strip lift),
- Quick approach of the tapping head and strip piloting.

Torque monitoring during tapping is available with the Servo-driven unit. It flags the detection of tapping anomalies / irregularities by an over-torque reading (tight pre-hole, tap worn out or lack of lubrication) or by a low-torque reading (tap breakage, large pre-hole).

ADVANTAGES:

This made-to-measure turnkey solution is adapted to your die environment:

- **The kinematics are totally controlled:** full guarantee of operation and optimized tapping speed.
- **The tapping station design is simplified and quick to implement.**
- **Simple to use:** no specific tooling with the head and motor positions guaranteed by indexing marks and lightened

head to ease its handling.

- **Integrated clutch system with a visual poka-yoke pin** for higher safety and reliability
- **Tapping torque reading to monitor tapping issues** (M5 and above with Servo-driven motorization), under certain conditions for multi-spindle units.
- **Automatic tap setup position for a quick, safe and easy installation** (Auto-Setup)

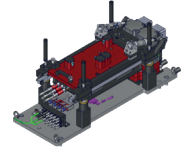
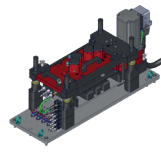
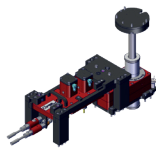

	TKN <i>Basic</i>	TKS <i>Essential</i>	TKD <i>Full featured</i>
Simplified motorization solid mounted on the lower shoe	M* or E**	M* or E**	M* or E**
Tapping direction	↓↑→	↓	↓
Kinematic	Fixed or mobile	Mobile	Fixed
Max Strip lift	100 mm	90 mm	90 mm
Tapping unit mini width	150 mm	185 mm	200 mm
Quick installation kit	●	●	●
Tapping station made by	Toolmaker	Pronic	Pronic
Embedded vertical strip movement	-	●	●
Strip guide	-	●	●
Adjustable gearbox	●	●	●
Integrated clutch system with a visual poka-yoke pin for higher safety and reliability	●	●	●
Tapping torque monitoring with servo-driven motorization and >M5 (conditions to be checked)	●	●	●
Tapping lubrication by micro-spraying	●	●	●
Lubrication of the tap by the center	○	○	○
Quick approach of the tapping head	-	-	●
Quick approach stroke	-	-	18 mm
Lower shoe of the tapping station	-	○	○
Piloting of the strip	○	○	○
Automatic tap setup position (Auto-Setup)	●**	●**	●**

● Série ○ Option - Not available *Mechanical **Electromechanical

CHARACTERISTICS:

Tap dimension ¹	M2,5 to M12
Max speed	120 spm
Maxi press stroke ² (mechanical motorization)	450 mm - 17.716"
Max strip lift (TKS & TKD)	45 mm - 1.771" /90mm - 3.543"
Width of the tapping device	150 mm - 5.905"

1 - BSP, TR, G, multi start threads...are also possible.
2 - For longer Tap travel, please contact us, we will use special lead screw

STRENGTHS:

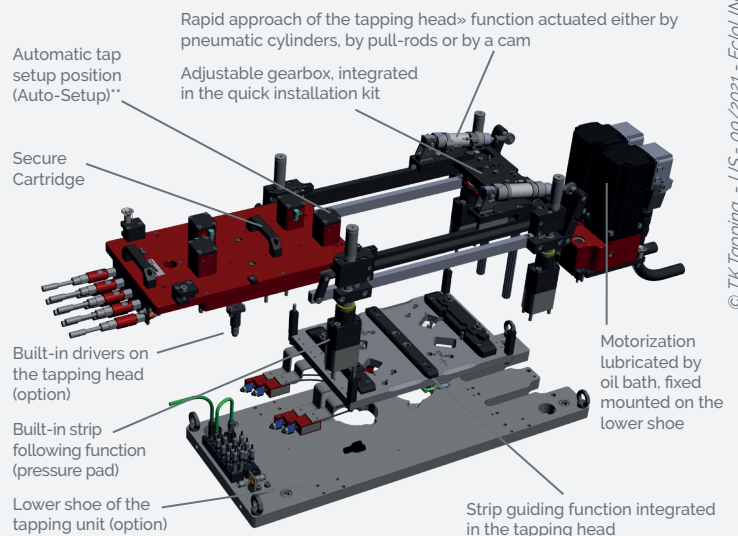

© TK Tapping - US - 09/2021 - EclolINK